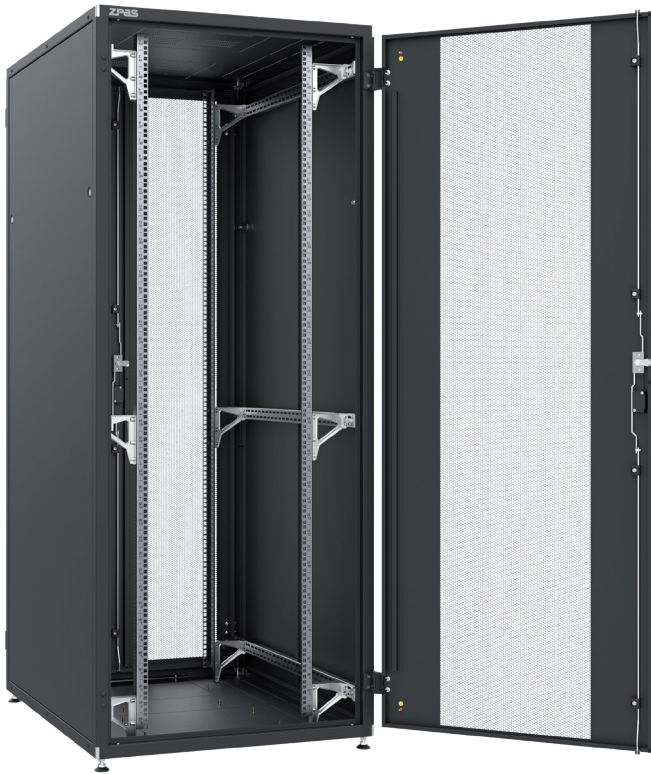

**SZB IT Server Cabinet 42 U, 800 x 1000 mm**

Catalogue number: W-IT-428010-45AA-2-161

**ZPAS****PRODUCT DESCRIPTION**

Cabinet for ICT applications based on a bolted frame. Static load capacity verified by external testing at 1500 kg.

**Functionality**

- 71 mm wide cable openings in the top and bottom plates allow to put through the power cords with three-phase plug.
- Ventilation perforation in the top plate.
- All openings in the top and bottom plates blanked with knock-out blanking plates.
- U-marking on the mounting profiles.
- Maximum opening angle for front and rear door: 270°
- Door opening direction can be changed.
- Possibility to put the cabinet directly on the floor (no protruding elements under the cabinet).
- Adaptation for joining the cabinets in the rows and Data Box creation (cold/hot aisle).
- Three-point locking system for cabinet doors.
- Doors with optimal perforation clearance of 80%.
- Adapted to a dense installation of active hardware.

**CONFIGURATION**

- Bolted frame (bottom plate, top plate, four posts).
- Front single-leaf perforated metal door.
- Rear double-leaf perforated metal door.
- Two solid metal side panels with single-point locks.
- Two pairs of 19" mounting profiles, type STANDARD.
- Earthing bar.
- Door and side panels earthing conductors (not shown in photos).
- Four levelling feet.

**TECHNICAL DATA****Material**

Frame, side panels, doors, mounting profiles, C-profiles – sheet steel.

Outriggers – zamak casting.

**Protection degree**

IP 20 in accordance with EN 60529.

**Surface finishing**

Frame, side panels, doors – powder paint, black (RAL 9005).  
Mounting profiles, C-profiles – zinc coated.



**SZB IT Server Cabinet 42 U, 800 x 1000 mm**

Catalogue number: W-IT-428010-45AA-2-161



A-A section

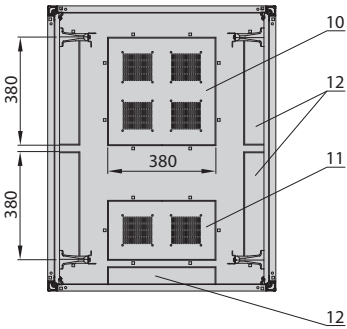

Front view

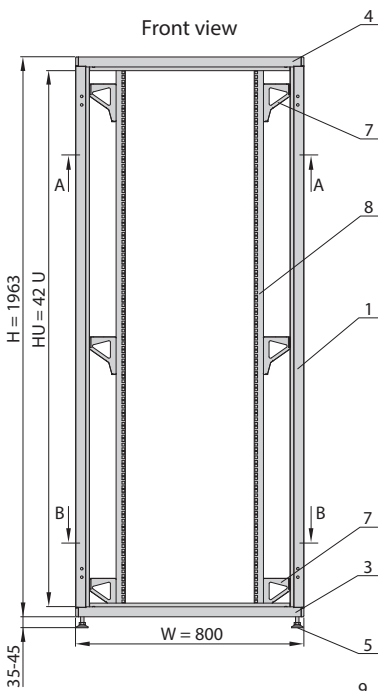

Side view

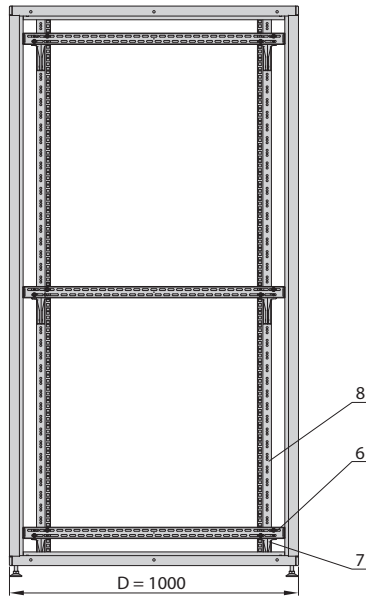

**DESIGN**

- 1. Frame's post
- 3. Frame's bottom plate
- 4. Frame's top plate
- 5. Adjustable feet
- 6. C-profile for 15 mm deep mounting profiles
- 7. Outrigger
- 8. 19" mounting profile, type STANDARD, 15 mm deep
- 9. Earthing bar
- 10. Knock-out blanking plate 380 x 380 mm
- 11. Knock-out blanking plate 380 x 210 mm
- 12. Knock-out blanking plate 380 x 71 mm

**Note:**

The cabinet in the drawing is shown without any panels or doors.

B-B section

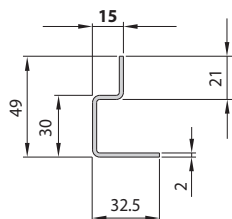
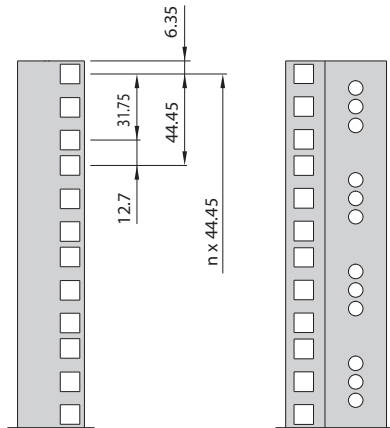
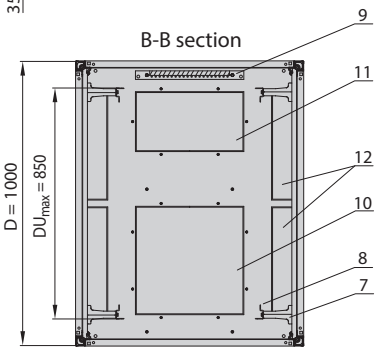

19" mounting profile  
type STANDARD  
15 mm deep